

BA24-TF way ball valve actuator

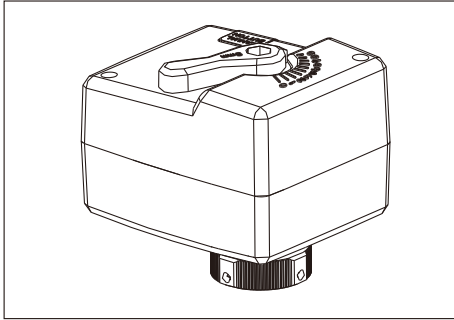

Dimensions [mm]

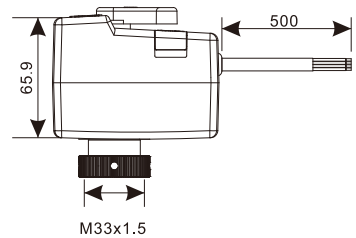
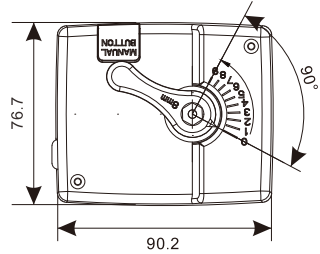

Main technical parameters

Function: 0~10VDC regulation feedback type;
manual adjustment

Voltage / Power: AC24V ; 50/60Hz

Running time motor: 45s/90°

Torque: 4Nm

Control signal: DC0~10V; DC4~20mA

Feedback signal: 0~10V DC (1mA)

Protection level: IP40

Wire specification: 4x0.5mm²;PVC;0.5m;black

Safety notes

- This device must not be used outside the specified field of application.
- Only authorised specialists may carry out installation. All applicable legal or institutional installation regulations must be complied during installation.
- The device may only be opened at the manufacturer's site. It does not contain any parts that can be replaced or repaired by the user.
- Cables must not be removed from the device.
- The device contains electrical and electronic components and must not be disposed of as household refuse. All locally valid regulations and requirements must be observed.

Dimensions [mm]

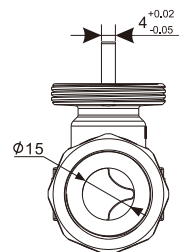
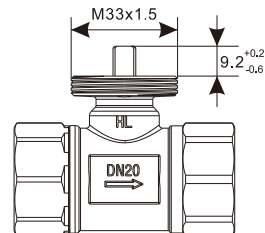

Accessories

阀门型号	Thread	Discharge coefficient Kvs	Value standard pressure MPa	Shut off pressure difference Mpa	Working medium	Medium temperature
BV20-A4	3/4"	6.5	2.0	0.6	Cold/hot water, 50% ethylene glycol solution	-20~95°C
BV25-A3	1"	10.3	2.5	0.6	Cold/hot water, 50% ethylene glycol solution	-20~95°C

Flow rate characteristic curve

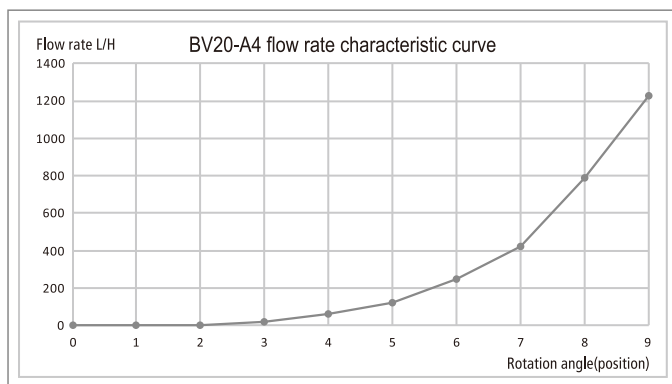

Wiring diagram

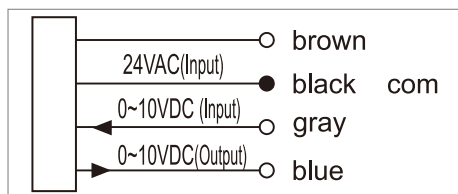

Maintenance

Ball valves and rotary actuators are maintenance-free.

Before any service work on the final controlling device is carried out, it is essential to isolate the rotary actuator from the power supply (by unplugging the electrical cable if necessary). Any pumps in the part of the piping system concerned must also be switched off and the appropriate slide valves closed (allow all components to cool down first if necessary and always reduce the system pressure to ambient pressure level).

The system must not be returned to service until the ball valve and the rotary actuator have been correctly reassembled in accordance with the instructions and the pipeline has been refilled by professionally trained personnel.